

2026 Big Sky Classic

WORKING COW HORSE PATTERN 4

Classes 13-22
Outdoor Arena *weather permitting*

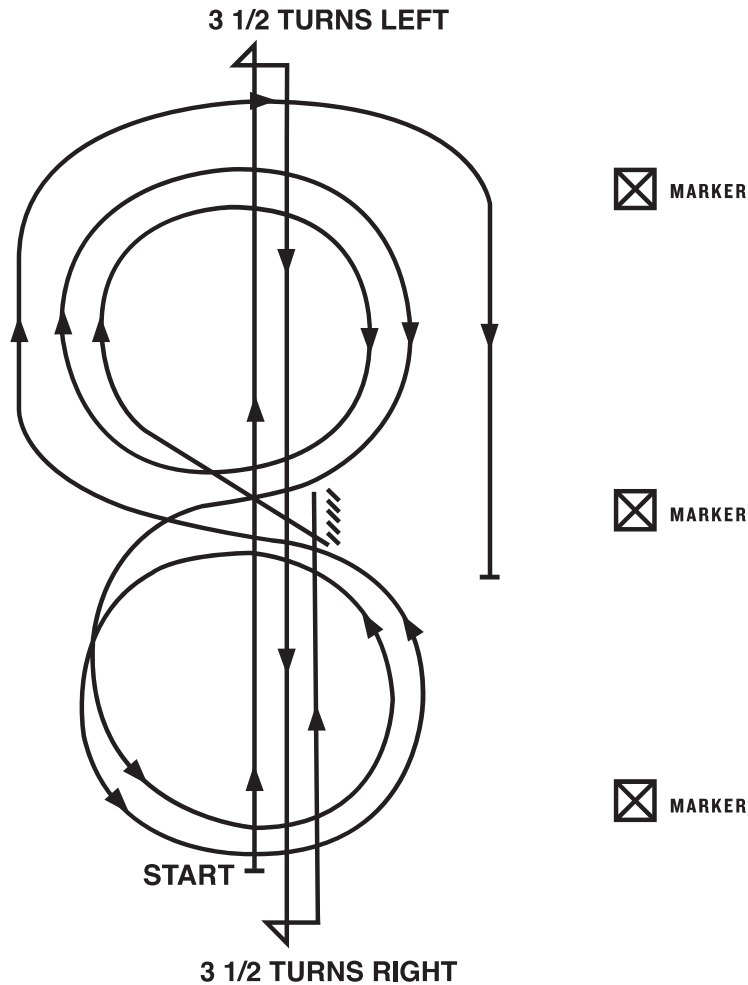

1. Start at end of arena. Run up center of arena past the end marker and come to a sliding stop.
2. Complete 3 1/2 spins to the left.
3. Run to other end of arena past the end marker and stop.
4. Complete 3 1/2 spins to the right.
5. Run past the center marker and stop. Back at least 10 feet. Complete 1/4 turn to the left, hesitate.
6. Begin on right lead. Circle to the right. Complete two circles to the right, the first one small and slow and the second large and fast. Change leads at the center of the arena.
7. Complete one small, slow circle and one large, fast circle. Change leads at the center of arena.
8. Run around end of arena to the other side, past the center marker, at least 20 feet from fence and come to a sliding stop. Hesitate to complete pattern.

PATTERN 4

- | | |
|-------------------------|------------------|
| 1. Stop | 6. Right circles |
| 2. 3 1/2 left spins | 7. Left circles |
| 3. Stop | 8. Stop |
| 4. 3 1/2 right spins | |
| 5. Stop and back up and | |

2026 Big Sky Classic

VRH AND RHC RANCH REINING PATTERN 7

Classes 23-38
Outdoor Arena *weather permitting*

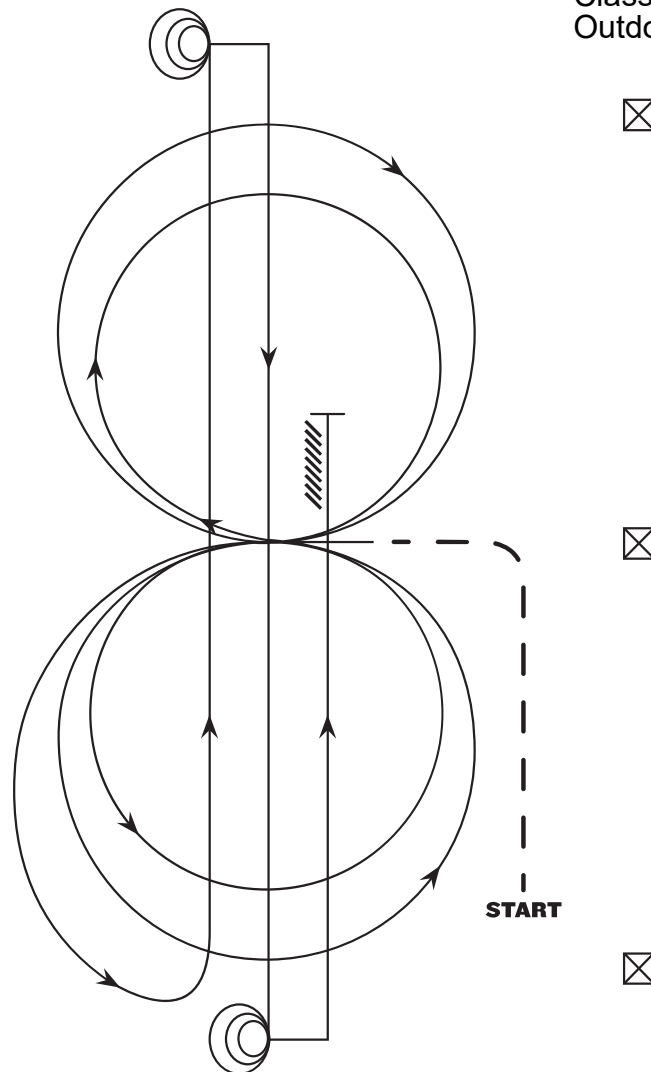

Mandatory Marker along Fence or Wall: The judge shall indicate with markers on arena wall or fence the center of pattern. Judge shall also place markers on fence or wall at least 50' from each end of the arena.

Ride pattern as follows: Trot to center of arena and stop or walk before departure. Start pattern facing toward judge.

1. Beginning on left lead, complete two circles to the left - the first one large and fast, the second one small and slow. Change leads at center of arena.
2. Complete two circles to the right - the first one large and fast, the second one small and slow. Change leads at center of arena.
3. Begin a circle to the left, but do not close this circle. Continuing around the end of arena, run up the center, past end marker, and do a sliding stop.
4. Complete 3 1/2 spins to the left.
5. Run down to other end of arena, past the end marker, and do a sliding stop.
6. Complete 3 1/2 spins to the right.
7. Run past the center marker and do a sliding stop. Back at least 10 feet. Hesitate to show completion pattern

2026 Big Sky Classic

Classes 39-45

REINING PATTERN 7

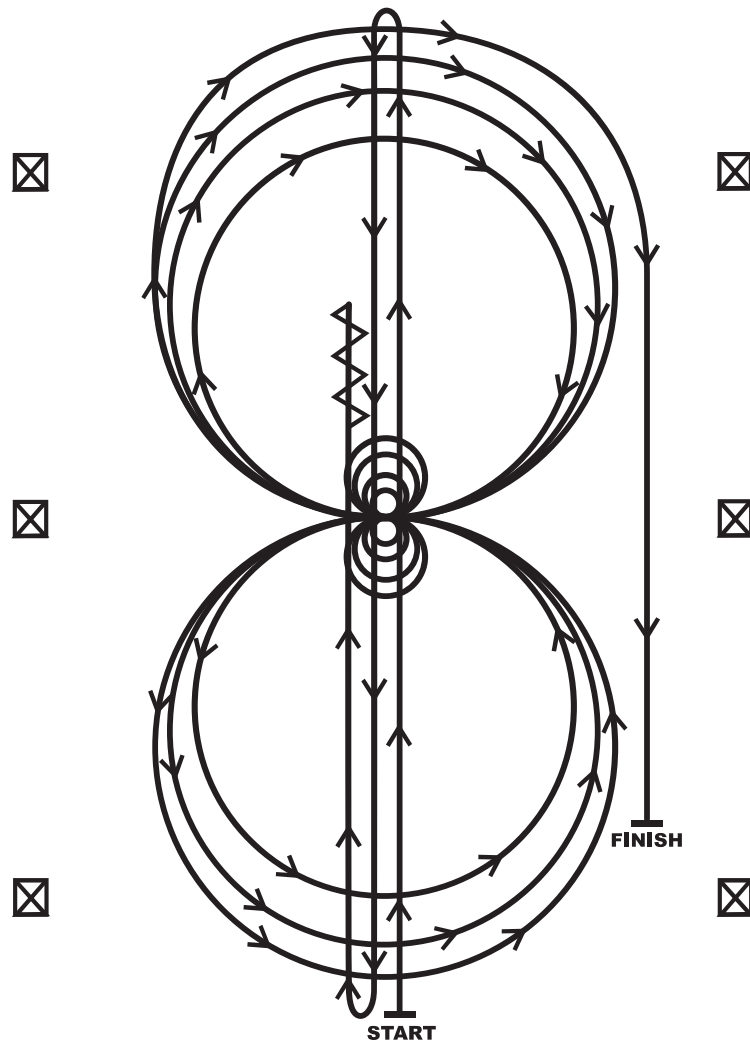

1. Run at speed to the far end of the arena past the end marker and do a left rollback—no hesitation.
2. Run to the opposite end of the arena past the end marker and do a right rollback—no hesitation.
3. Run past the center marker and do a sliding stop. Back up to the center of the arena or at least ten feet (three meters). Hesitate.
4. Complete four spins to the right. Hesitate.
5. Complete four and one-quarter spins to the left so that horse is facing left wall or fence. Hesitate.
6. Beginning on the right lead, complete three circles to the right: the first two circles large fast; the third circle small and slow. Change leads at the center of the arena.
7. Complete three circles to the left: the first two circles large fast; the third circle small and slow. Change leads at the center of the arena.
8. Begin a large circle to the right but do not close this circle. Run straight down the right side of the arena past the center marker and do a sliding stop at least twenty feet (six meters) from the wall or fence. Hesitate to demonstrate completion of the pattern.

2026 Big Sky Classic

RANCH RIDING - PATTERN 10

Classes 46-54

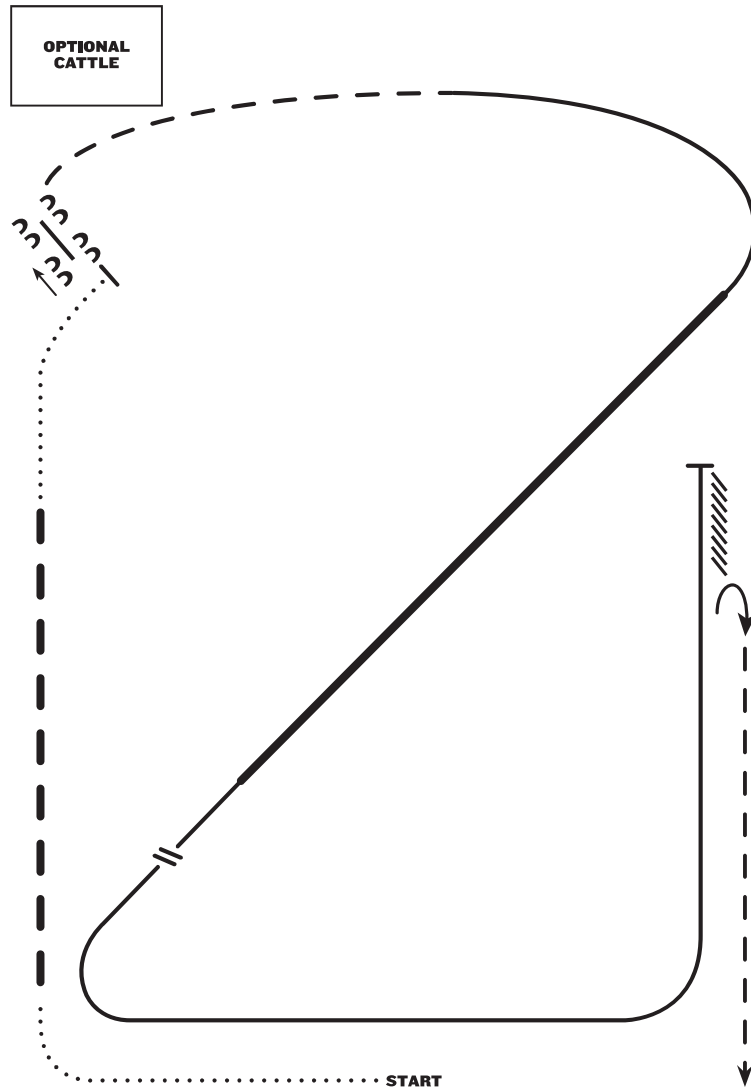

LEGEND	
----	Walk
- - - -	Extended Walk
- · - ·	Trot
- · - · - ·	Extended Trot
—	Lope
— · — ·	Extended Lope
////	Back
∩	Lead Change

1. Walk
2. Extended trot
3. Walk
4. Stop, side pass left over log
5. Trot
6. Lope right lead
7. Extended lope right lead
8. Collect lope and change leads (simple or flying)
9. Lope left lead
10. Stop and back
11. 1/2 turn right
12. Trot

Note: The drawn description of this pattern is only intended for the general depiction of the pattern. Exhibitors should utilize the arena space to best exhibit their horses.

2026 Big Sky Classic

Classes 66, 68, 70, 72, 74, 76, 78, 80

OPTIONAL VRH AND RHC RANCH RIDING PATTERN 2

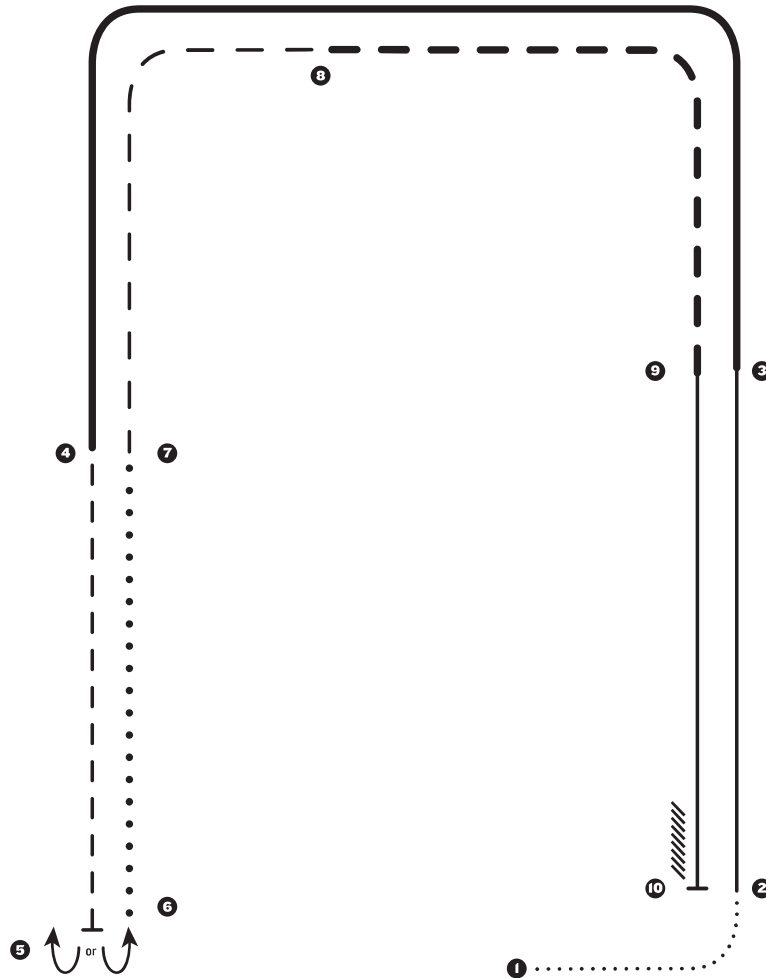

LEGEND	
.....	Walk
-----	Extended Walk
-----	Trot
-----	Extended Trot
-----	Lope
-----	Extended Lope
///////	Back

When establishing the course, the following distances are suggested. Patterns may begin in either direction and markers are optional.

1. Walk from 1 to 2 - 30 feet
2. Lope from 2 to 3 - 150 feet
3. Extended Lope from 3 to 4 - 200 feet
4. Trot from 4 to 5 - 120 feet
5. Stop at 5; reverse (either direction)
6. Extended Walk from 6 to 7 - 75 feet
7. Trot from 7 to 8 - 90 feet
8. Extended Trot from 8 to 9 - 240 feet
9. Lope from 9 to 10 - 150 feet
10. Stop and Back at 10 - approximately one horse length

Note: The drawn description of this pattern is only intended for the general depiction of the pattern. Exhibitors should utilize the arena space to best exhibit their horses.

2026 Big Sky Classic

Classes 59-65
Classes 67, 69, 71, 73, 75, 77, 79, 81

Ranch Trail

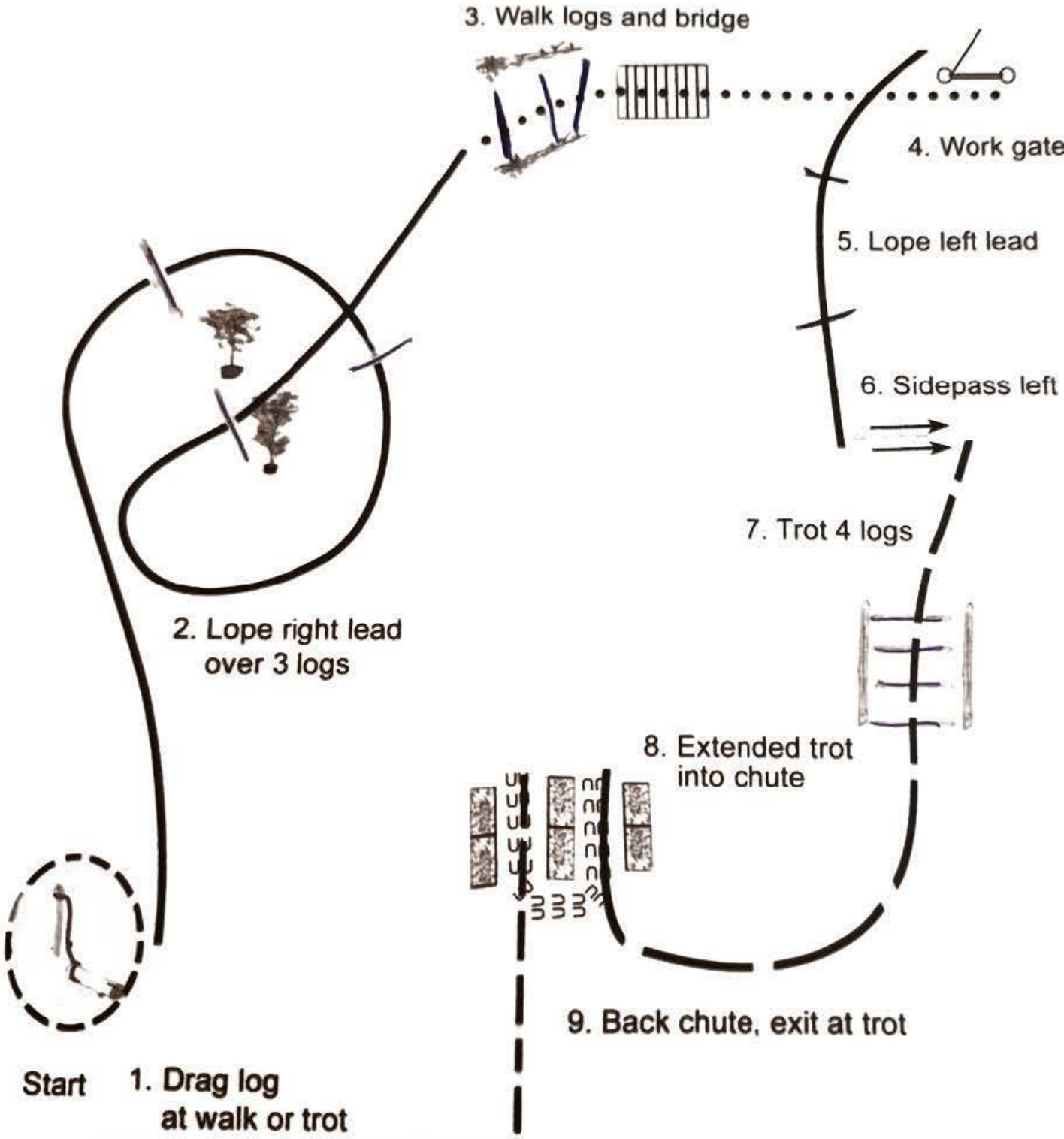

Youth, Level 1, and Rookie OMIT

2026 Big Sky Classic Showmanship (Small Fry)

Class 148

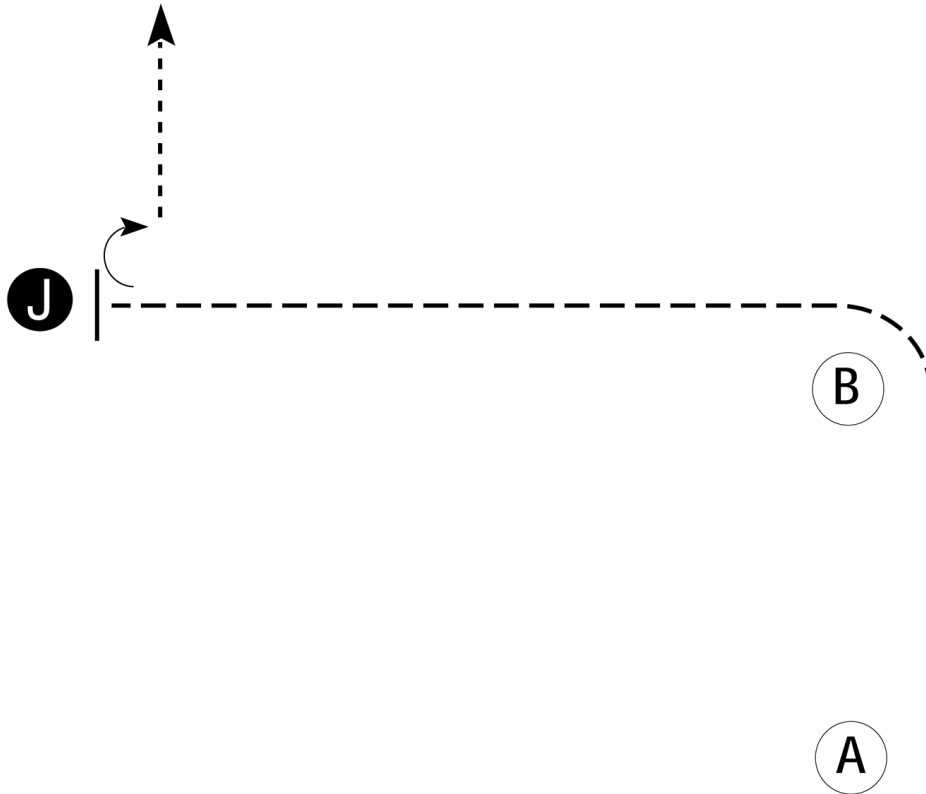

Be ready at A.

1. Walk from A to B.
2. At B, trot to judge.
3. Stop and set up for inspection.
4. When dismissed, turn 90 degrees and walk away from judge.
5. Follow the instructions of your ring steward.

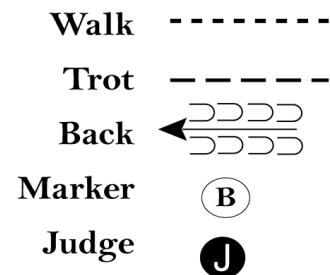

[S/WT-11]

Pattern Provided by:
Marv and Sue Kapushion

w w w . H o r s e S h o w P a t t e r n s . c o m

w w w . H o r s e S h o w P a t t e r n s . c o m

2026 Big Sky Classic

Showmanship (All Breed, Youth, Amateur, and Select)

Class 147, 151, 154, 155

w w w . H o r s e S h o w P a t t e r n s . c o m

w w w . H o r s e S h o w P a t t e r n s . c o m

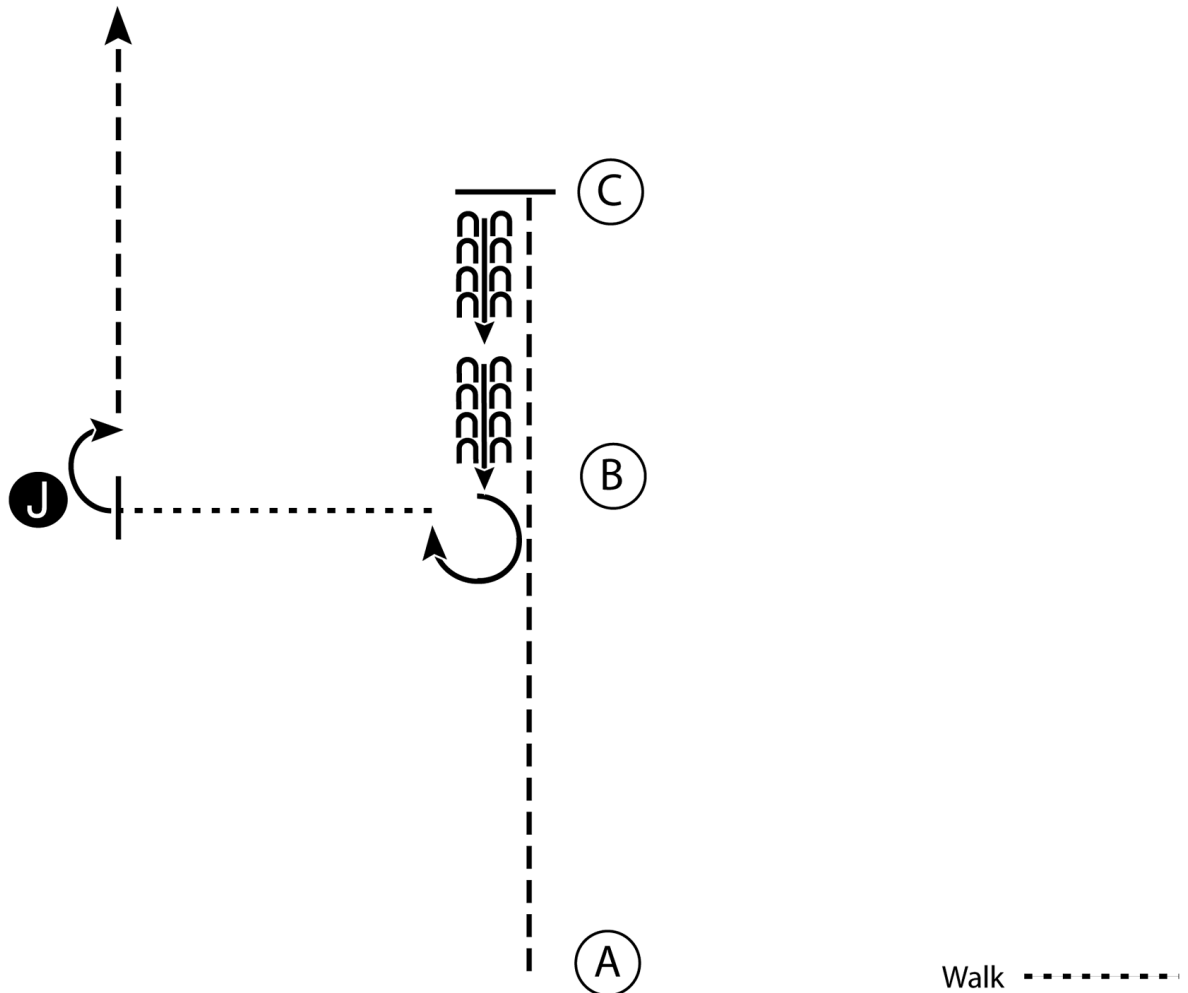

1. Trot from A to C.
2. Stop and back to B.
3. Perform a 270 degree turn and walk to the Judge.
4. Stop and set up for inspection.
5. When dismissed perform a 90 degree turn and trot to line-up.

- Walk
Trot - - - - -
Back ← ← ← ← ←
Marker (B)
Judge (J)

[S/2-14]

Pattern Provided by:

Marv and Sue Kapushion

2026 Big Sky Classic

Showmanship (Rookie & Level 1)

Rookie & Level 1 Held Concurrently Classes 149-150, 152-153

w w w . H o r s e S h o w P a t t e r n s . c o m

w w w . H o r s e S h o w P a t t e r n s . c o m

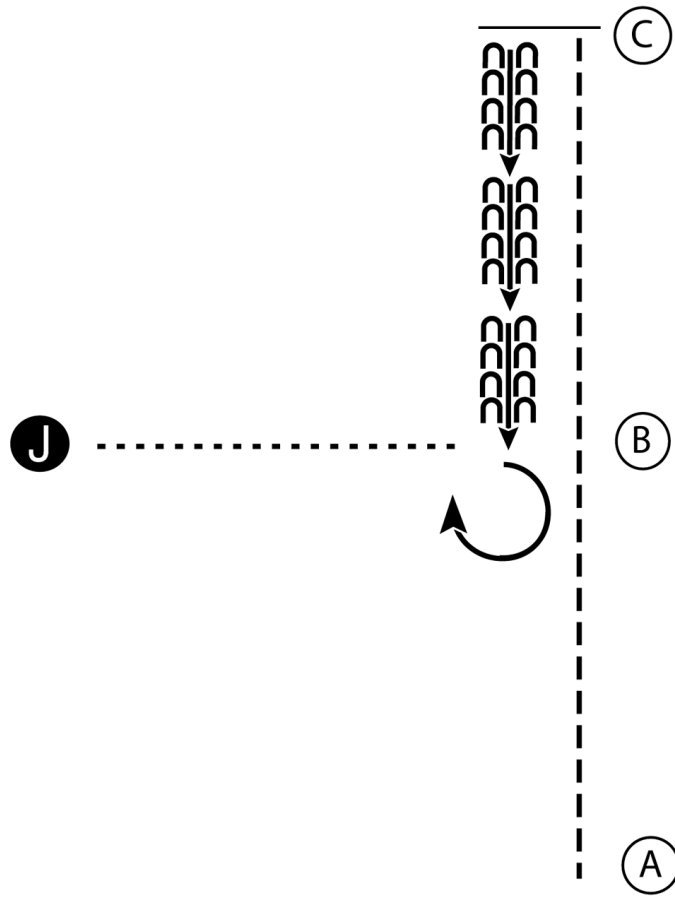

1. Trot from A to C.
2. Stop at C.
3. Back to B.
4. Perform a 270 degree turn.
5. Walk to the judge and set up for inspection.
6. When dismissed walk to line-up.

Walk
 Trot - - - - -
 Back ← 
 Marker (B)
 Judge (J)

[S/1-3]

Pattern Provided by:
Marv and Sue Kapushion

2026 Big Sky Classic

Horsemanship (Walk Trot, Small Fry)

Classes 170, 171, 175

w w w . H o r s e S h o w P a t t e r n s . c o m

w w w . H o r s e S h o w P a t t e r n s . c o m

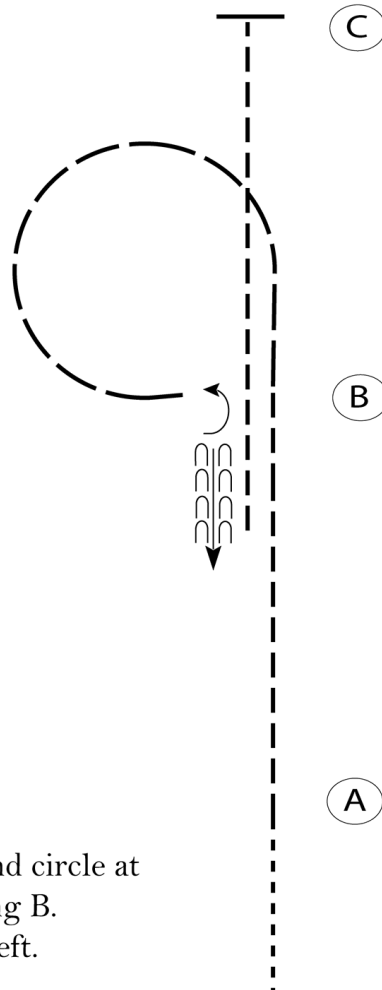

- Begin before A at a walk.
1. Jog from A to B.
 2. At B, extend the jog and circle at B as shown. Stop facing B.
 3. Turn 1/4 turn to the left.
 4. Back one horse length.
 5. Jog to C. Stop at C.

Follow the instructions of your ring steward.

Walk	-----
Jog	-----
Extended Jog	-----
Lope	—————
Leg Yield	
Lead Change	—/—
Back	←←←←← ←←←←←
Marker	Ⓚ
Sidepass	←-----→

[WH/WT-17]

Pattern Provided by:
Marv and Sue Kapushion

2026 Big Sky Classic

Horsemanship (Rookie & Level 1)

Rookie & Level 1 Held Concurrently Classes 172-173, 176-177

w w w . H o r s e S h o w P a t t e r n s . c o m

w w w . H o r s e S h o w P a t t e r n s . c o m

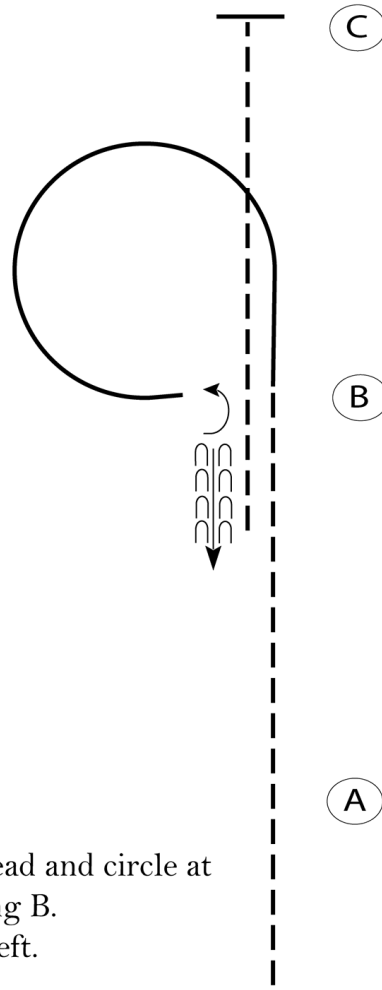

Begin before A at a jog.

1. Jog from A to B.
2. At B, lope on the left lead and circle at B as shown. Stop facing B.
3. Turn 1/4 turn to the left.
4. Back one horse length.
5. Jog to C. Stop at C.

Follow the instructions of your ring steward.

Walk	-----
Jog	- - - - -
Extended Jog	- - - - -
Lope	—————
Leg Yield	
Lead Change	— / —
Back	← C C C C C
Marker	Ⓚ
Sidepass	←-----→

[WH/1-17]

Pattern Provided by:
Marv and Sue Kapushion

2026 Big Sky Classic

Horsemanship (All Breed, Youth, Amateur, and Select)

Classes 169, 174, 178, 179

www.HorseShowPatterns.com

www.HorseShowPatterns.com

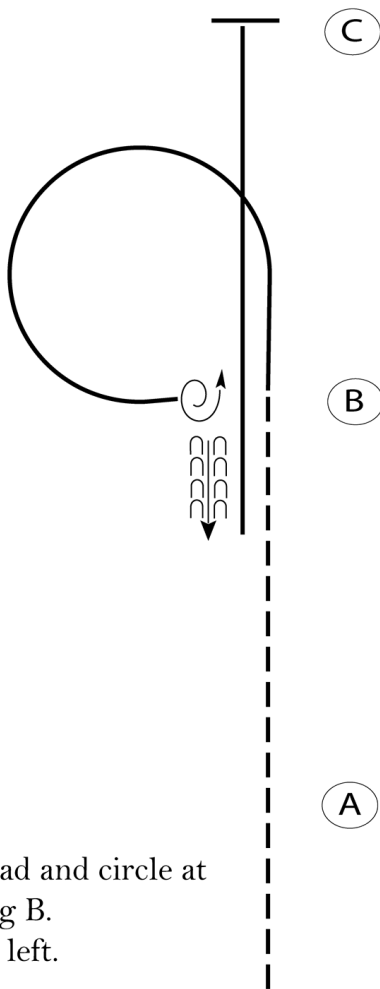

Begin before A at a jog.

1. Jog from A to B.
2. At B, lope on the left lead and circle at B as shown. Stop facing B.
3. Turn 1 1/4 turn to the left.
4. Back one horse length.
5. Lope on the right lead to C. Stop at C.

Follow the instructions of your ring steward.

Walk	-----
Jog	-----
Extended Jog	-----
Lope	—————
Leg Yield	
Lead Change	—/—
Back	← C C C C C C C C C C
Marker	Ⓚ
Sidepass	←-----→

[WH/2-17]

Pattern Provided by:

Marv and Sue Kapushion

2026 Big Sky Classic

Trail

Classes 180 - 193

Rookie & Level 1 Held Concurrently

Yearling, Small Fry, & Walk Trot: Jog for the lope and walk for the Jog

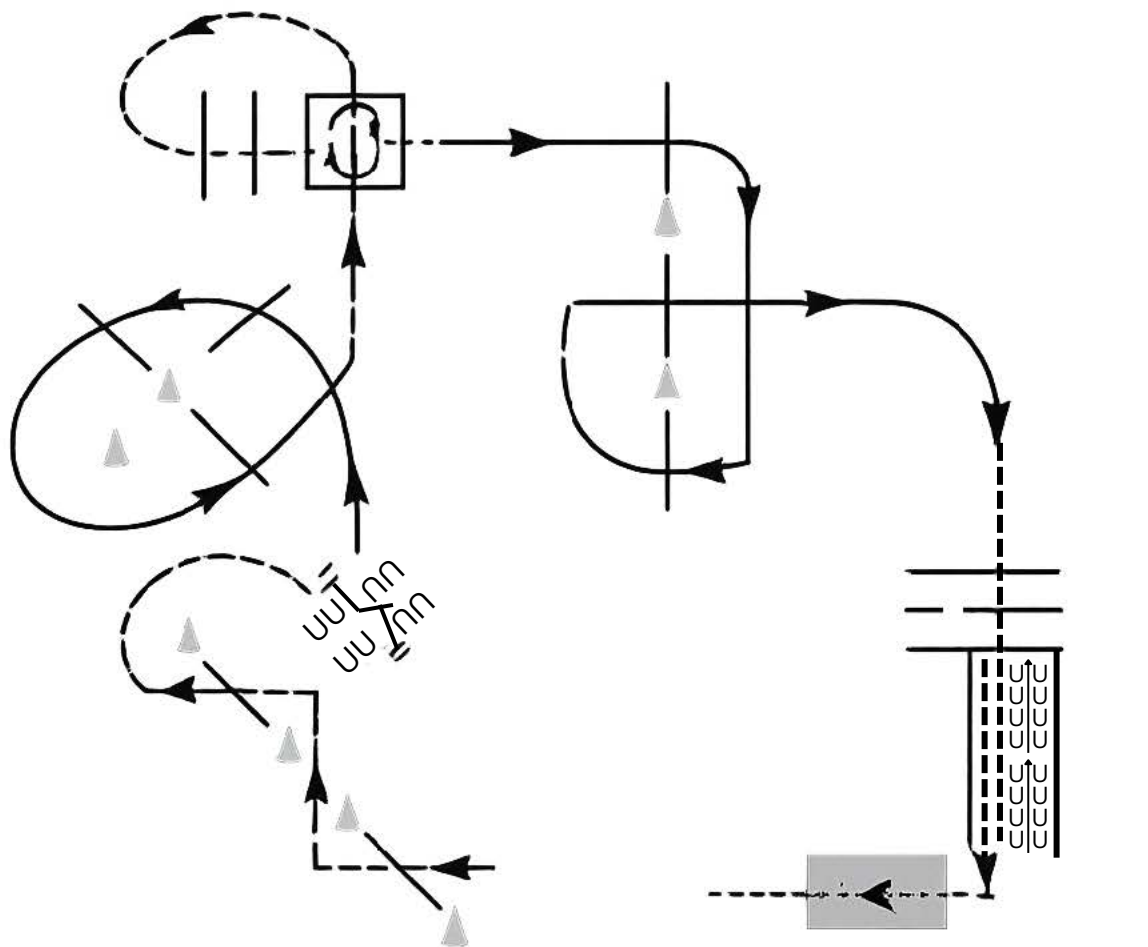

1. Jog over poles as shown
2. Work gate with left hand
3. Lope on left lead over poles
4. Jog thru box, over poles and into box
5. Turn 360 degrees to the right and walk out
6. Lope on right lead over poles
7. Walk over poles and into chute; back the chute
8. Walk out of chute and over bridge to finish

Walk	-----
Jog	- - - - -
Extended. log	- - - - -
Lope	—————
Leg Yield	+++++++
Lead Change	↗ ↘
Back	⤵ ⤵ ⤵ ⤵ ⤵ ⤵
Marker	(B)
Sidepass	← - - - - ←

2026 Big Sky Classic

LEVEL 1 WESTERN RIDING PATTERN 2

Rookie & Level 1
Classes 195-197, 200-201

Rookie & Level 1 Held Concurrently

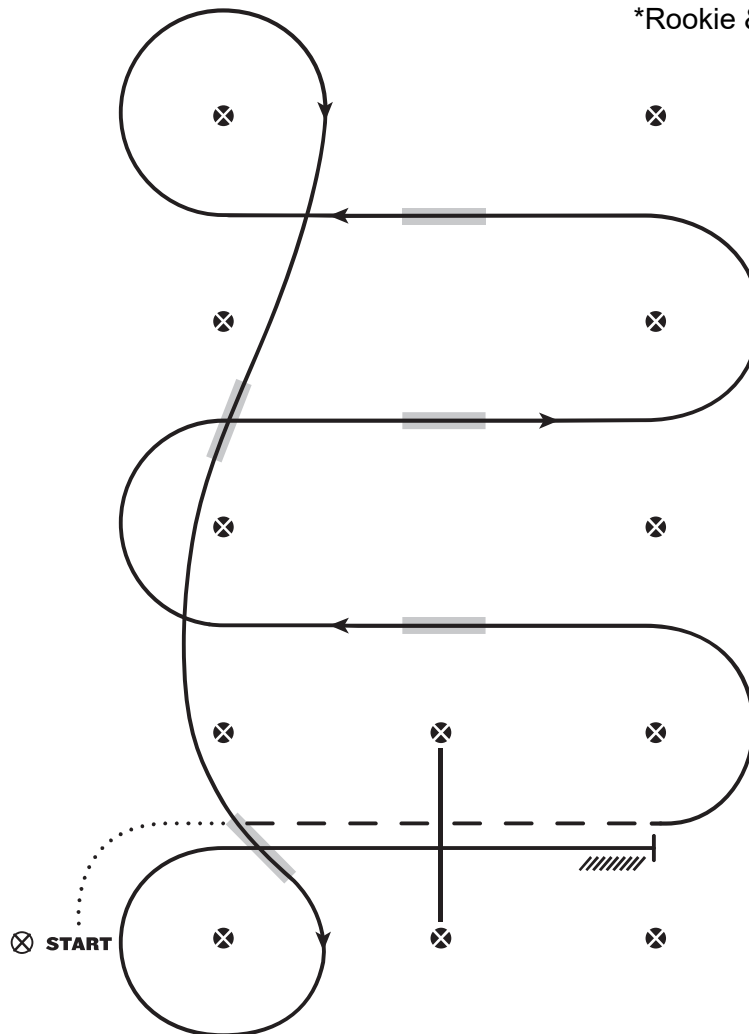

LEGEND

----	Walk
- - - -	Jog
————	Lope
////	Back
■	Lead Changing Area

1. Walk at least 15 feet from start cone to the first marker, as drawn, transition to jog, jog over log.
2. Transition to the lope left lead
3. First crossing change
4. Second crossing change
5. Third crossing change
6. Circle & first line change
7. Second line change & circle
8. Lope over log
9. Stop & back

2026 Big Sky Classic

Hunt Seat Equitation (Walk Trot & Small Fry)

Classes 218, 219, 223

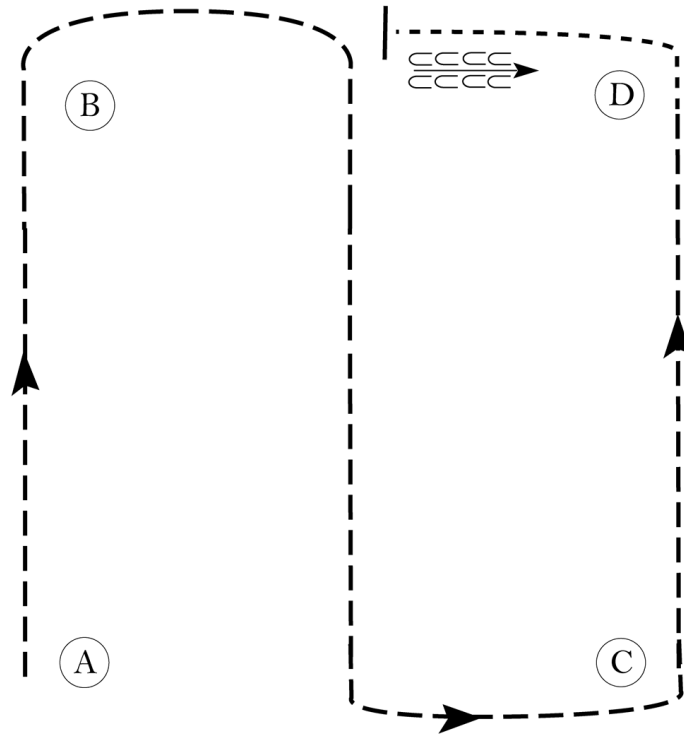

Be ready at A.

1. Posting trot to and around B on the left diagonal.
2. Halfway between B and C, change diagonals.
3. Posting trot on the right diagonal to and around C.
4. Continue to trot to D.
5. At D, walk.
6. Walk until halfway to B, stop and back one horse length.

Walk	-----
Trot	- - - - -
Extended Trot	— — — — —
Canter	—————
Leg Yield	
Lead Change	— / —
Back	← ← ← ← ←
Marker	Ⓚ
Sidepass	← — — — — ←
Hand Gallop	— — — — —

[HSE/WT-25]

Pattern Provided by:

Marv and Sue Kapushion

www.HorseShowPatterns.com

www.HorseShowPatterns.com

2026 Big Sky Classic

Hunt Seat Equitation (Rookie & Level 1)

Rookie & Level 1 Held Concurrently Classes 220-221, 224-225

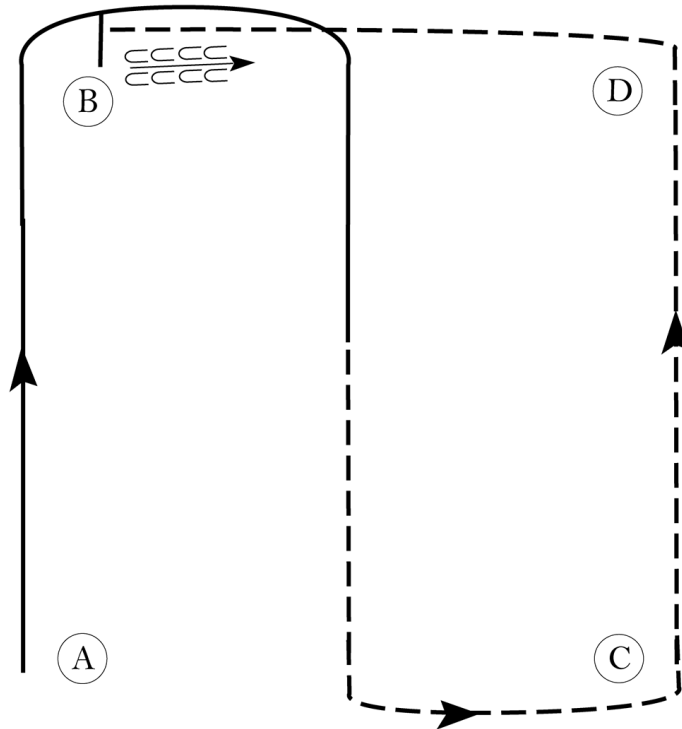

Be ready at A.

1. Canter on the right lead to and around B.
2. Halfway between B and C, break to the trot.
3. Posting trot on the right diagonal to C.
5. At C, change diagonals and continue to trot to D.
6. At D, sitting trot to B.
7. At B, stop and back one horse length.
at end of pattern walk away

Walk	-----
Trot	- - - - -
Extended Trot	— — — —
Canter	—————
Leg Yield	
Lead Change	↙ ↘
Back	←←←←
Marker	Ⓚ
Sidepass	← — — — →
Hand Gallop	— — — —

[HSE/1-25]

Pattern Provided by:

Marv and Sue Kapushion

w w w . H o r s e S h o w P a t t e r n s . c o m

w w w . H o r s e S h o w P a t t e r n s . c o m

2026 Big Sky Classic

Hunt Seat Equitation (All Breed, Youth, Amateur, and Select)

Classes 217, 222, 226, 227

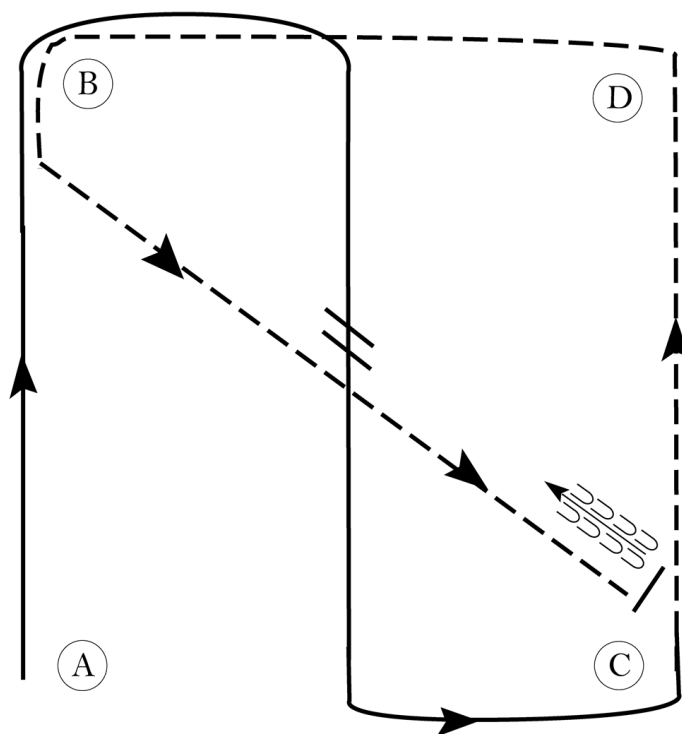

Be ready at A.

1. Canter on the right lead to and around B.
2. Halfway between B and C, change leads.
3. Canter on left lead to and around C.
4. Posting trot on the left diagonal from C to D.
5. At D, change diagonals and continue to trot to B.
6. At B, sitting trot to C.
7. Stop and back one horse length at C.

at end of pattern walk away

Walk	-----
Trot	- - - - -
Extended Trot	— — — — —
Canter	—————
Leg Yield	
Lead Change	— / —
Back	←←←←←
Marker	⊖
Sidepass	← — — — — ←
Hand Gallop	— — — — —

[HSE/2-25]

Pattern Provided by:

Marv and Sue Kapushion

www.HorseShowPatterns.com

www.HorseShowPatterns.com